

MaxDim Installation Instructions

PARTS SUPPLIED:

- 1 ea Dimmer Control P/N 9100-001, including STC logbook copy
- 1 ea Fully Insulated Red Female Solderless Crimp on Connectors for 16-22 AWG Wire.
- 2 ea Fully Insulated Blue Female Solderless Crimp on Connectors for 14-16 AWG Wire.
- 1 ea Reference Panel Label
- 1 ea Install Template
- 1 ea Knob

NEW INSTALLATION:

1. Locate a convenient place for the Dimmer Control. Using the Template provided, drill two holes. Drill the first one (3/8") at the location where the center of the Dimmer is desired. Drill the second (anti-rotation) hole (1/8") offset to the left from the first 3/8".
2. Determine the current that the circuit will be required to carry.
3. Test Position the Dimmer Control and determine the length of the wires required.
4. Remove the Dimmer Control and proceed with the installation. From the **WIRE SIZE-CURRENT CAPACITY TABLE**, select the wire size required. If the installation is in an Aircraft, use only MIL-W-16878E/4 Type E, Teflon insulated, Silver-Plated Copper Wire, or equivalent.
5. Find the location of the power source.
6. Install a 15 amp breaker for the dimming circuit power source.
7. Run a Red wire from the Breaker to the MaxDim controller positive (POS) terminal, then Select and install a Red or Blue Female Solderless Crimp on Connector, for the wire size used, on the end of the red wire. Push the female connector onto the positive male connector on the MaxDim controller.
8. Using the same technique that was used with the Red wire, run a Black wire from the male connector terminal on the MaxDim to system ground. The common (Gnd) Wire is simply a signal wire used by the unit. It does not carry heavy currents during operation. Use a Red Female Solderless Crimp on Connector for this wire.
9. Again using the same technique that was used with the Red wire, run a Blue wire from output CKT for the dimming circuit. Select and install a Red or Blue Female Solderless Crimp on Connector, for the wire size used, on the end of the Blue wire and push it onto the male connector on the MaxDim Controller.
10. With the Dimmer Control inserted from the rear into the 3/8" drilled hole and with the reference label placed over the threads on the Dimmer Control, install a washer and a nut to hold the Dimmer Control in place. Before tightening the nut, insure that the anti-rotation plastic bump is seated in the 0.150 in (#25) hole and the reference Label is vertically aligned.
11. Install the knob using a small screw driver.

EXISTING/REPLACEMENT INSTALLATION:

1. Locate a convenient place for the Dimmer Control. Using the Template provided, drill two holes. Drill the first one (3/8") at the location where the center of the Dimmer is desired. Drill the second (anti-rotation) hole 0.150 in (#25) offset to the left from the first 3/8".
2. Determine the Positive supply, Dimmer circuit, and chassis ground wiring.
3. Test Position the Dimmer Control and determine if an additional the lengths of the wires required.
4. Insure that a 15 amp breaker for the MaxDim Dimmer Controller power source is installed in series with power source.

5. Remove the Dimmer Control and proceed with the installation. From the wire size-current capacity table, select the wire size required if additional wire is required. If the installation is in an Aircraft, use only MIL-W-16878E/4 Type E, Teflon insulated, Silver-Plated Copper Wire, or equivalent.
6. Run Red wire from the Breaker to the MaxDim controller positive (POS) terminal, then Select and install a Red or Blue Female Solderless Crimp on Connector, for the wire size used, on the end of the red wire. Push the female connector onto the positive male connector on the MaxDim controller.
7. Using the same technique that was used with the Red wire, run a Black wire from the male connector terminal on the MaxDim to system ground. The common (Gnd) Wire is simply a signal wire used by the unit. It does not carry heavy currents during operation. Use a Red Female Solderless Crimp on Connector for this wire.
8. Again using the same technique that was used with the Red wire, run Blue wire from output CKT for the dimming circuit. Select and install a Red or Blue Female Solderless Crimp on Connector, for the wire size used, on the end of the Blue wire and push it onto the male connector on the MaxDim Controller.
9. With the Dimmer Control inserted from the rear into the 3/8" drilled hole and with the reference label placed over the threads on the Dimmer Control, install a washer and a nut to hold the Dimmer Control in place. Before tightening the nut, insure that the anti-rotation plastic bump is seated in the 1/8" hole and the reference Label is vertically aligned.
10. Install the knob using a small screw driver.

FUNCTIONAL TEST:

1. Turn the knob fully counter clockwise and apply power to the system.
2. Slowly rotate the knob clockwise. The Lamp Dimmer Circuit will activate and with a continued clockwise rotation the lamps will increase in intensity.
3. Fully Clockwise rotation applies the full voltage to the Lamp Dimmer Circuit.
4. Fully Counterclockwise removes the voltage from the Lamp Dimmer Circuit.
5. The Lamp Dimmer Circuit voltage is continuously variable from off to full on.

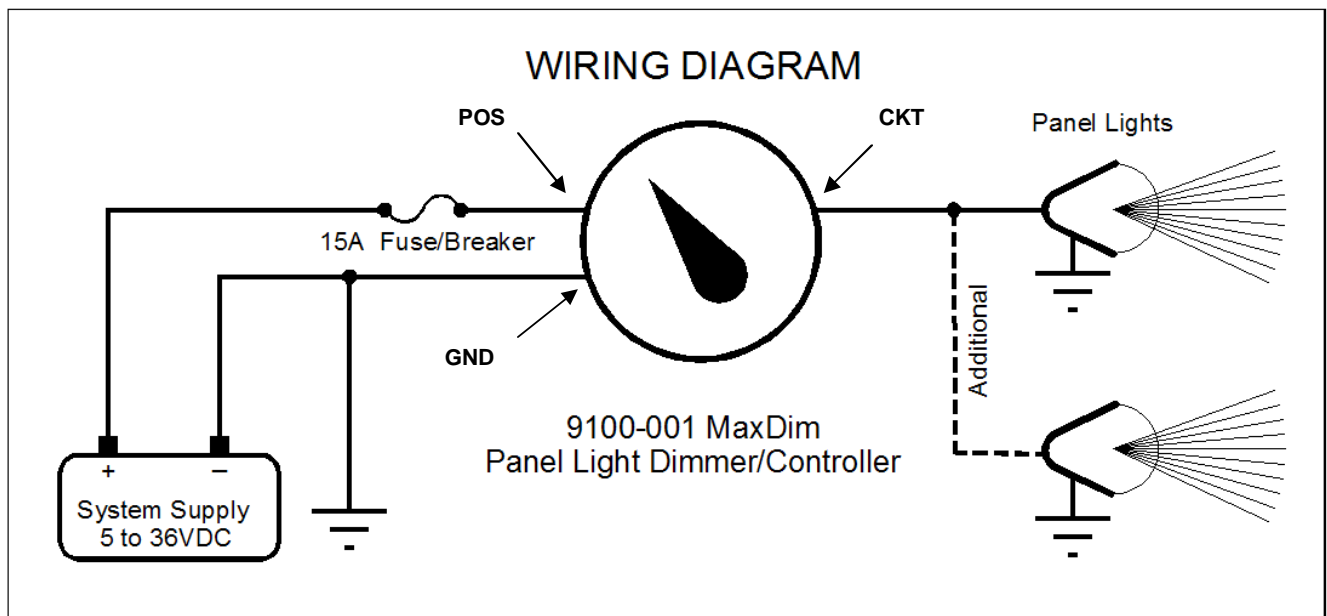

—SPECIFICATIONS—

Voltage Range: 5 to 35VDC

Max Current: 12.5 A

Controlled Output: 0 to 5/35 VDC
0 to 12.5A

Capacity:

- 60 Watts @ 5 VDC
- 150 Watts @ 12 VDC
- 300 Watts @ 24 VDC
- 350 Watts @ 28 VDC

Operating Temperature range: -30°C to +65°C

Internal Temperature Protect: +85°C

Storage Temperature: -40°C to +100°C

Maximum Internal Temperature: @ 12.5 A
+15 °C above Ambient.

Enclosure Material: Bayer FR 110 Resin

Meets UL 94 Flame Rating: V-2 (0.03in) V-0 (0.059in) 5VB (0.098in) 5VA (0.13in)



Approvals: FAA PMA STC SA01800SE

RTCA/DO-160E Tested/Qualified EMC

Potentiometer Rotation: 270 Deg,

Rotational Life: 500KTurns

Order P/N 9100-001-A

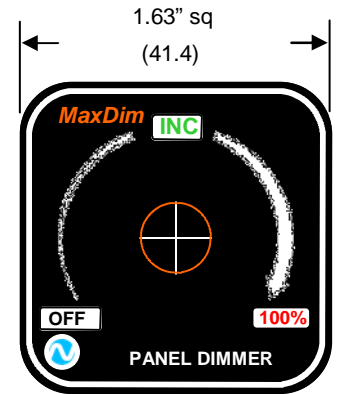
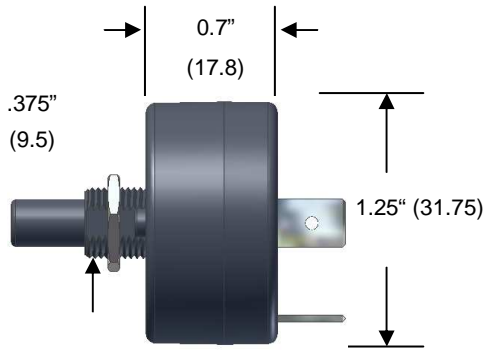

Note: Placard is not adhesive backed.



Seaton Engineering Corp.

Spokane Valley, WA 99016

509.928.0633

ONE YEAR LIMITED WARRANTY

SEC will repair or replace, at its expense and at its option any device manufactured by SEC which in the normal use has proven to be defective in workmanship or material, provided that the customer returns the product prepaid to SEC along with proof of purchase of the product within one year and provides SEC with reasonable opportunity to verify the alleged defect by inspection. SEC will not be responsible for any asserted defect which has resulted from misuse, abuse or over stressing above the published specifications. SEC will under no circumstances be liable for incidental or consequential damages resulting from the defective products. This warranty is SEC's Sole warranty and sets forth the customer's exclusive remedy, with respect to defective products; all other warranties, express or implied, whether of merchantability, fitness for purpose, or otherwise, are expressly disclaimed by SEC.

Seaton Engineering Corp. Spokane Valley, WA

CAUTION

Most EFIS, GPS, etc. equipment with screens have their own dimmer control and only the steam gauge instruments and panel lights are controlled by the independent dimmer controller. However, the installing technician and the owner must perform a post installation check for proper function and verification of compatibility with any existing equipment that might appear on these airplanes. With the possibility that there might be Electronic Flight Instrument Systems (EFIS) tied into the existing dimmer circuitry, the FAA has advised that the installing Technician and owner verify that they cannot dim any (EFIS) all the way to zero, so there is no danger of failure of this simple dimmer causing all the (EFIS) displays/instruments to be black. If this incompatibility exists the (EFIS) must be removed from the dimming circuit.

FAA REQUIREMENTS

Amend the weight and balance records and make the necessary log book entry. Complete an FAA form 337 showing the installation of this equipment in accordance with the STC instruction and submit one copy to the FAA and one copy to the aircraft owner. File all data and a copy of the STC with the aircraft records.

INSTRUCTIONS FOR CONTINUED AIRWORTHINESS

The Airworthiness Limitations section is FAA approved and specifies maintenance required under Part 43.16 and 91.403 of the FAR's unless and alternative program has been FAA approved. **Airworthiness Limitation:** MaxDim P/N 9100-001-A Light Dimmer Controller, manufactured by Seaton Engineering Corporation has no repairable parts and if a failure occurs, the part must be replaced in its entirety.

General Engineering Data Regarding Wire Sizes and Current Capacities Capacity Data
WIRE AND CABLE DERATING CRITERIA FROM MIL-STD-975

AWG	Diameter	Diameter	Ohms Per	Ohms Per	Maximum	AWG	Derated Current	
Gauge	Inches	mm	1000 Ft	km	Ampere	Gauge	Single	Bundled
14	0.0641	1.6281	2.525	8.282	32	14	19.0	8.5
15	0.0571	1.4503	3.184	10.4435	28	15	16.6	7.4
16	0.0508	1.2903	4.016	13.1725	22	16	13.0	6.5
17	0.0453	1.1506	5.064	16.6099	19	17	11.2	5.6
18	0.0403	1.0236	6.385	20.9428	16	18	9.2	5.0
19	0.0359	0.9119	8.051	26.4073	14	19	8.1	4.4
20	0.032	0.8128	10.15	33.292	11	20	6.5	3.7
21	0.0285	0.7239	12.8	41.984	9	21	5.3	3.0
22	0.0254	0.6452	16.14	52.9392	7	22	4.5	2.5