

Dual MaxDim Installation Instructions

P/N 9100-001-D

PARTS SUPPLIED 9100-001-D:

- 1 ea Dual MaxDim Control P/N 9100-001-D, including STC logbook copy
- 1 ea Fully Insulated Red Female #6 Crimp on Ring Lug Connector for 16-22 AWG Wire.
- 3 ea Fully Insulated Blue Female #6 Crimp on Ring Lug Connectors for 14-16 AWG Wire.
- 4 ea 6-32 X 1/4 Button Head Socket SS screws including #6 SS Internal Star Washer
- 1 ea 5/64 in Long Handle Key Allen Wrench
- 1 ea Panel Placard
- 1 ea Install Template
- 1 ea Dual Knob Set with Long Handle Hex Key

9100-001-D WIRING:

1. ***The installer should insure that each circuit is properly protected.*** Determine total current required by the loads. Multiply by 1.2, then Select the next higher rated breaker for use with your Dual MaxDim. In most cases only F1 will be required. This is determined by your wiring size and breaker sizing. For instance, if your total required current is 8 amps, the breaker you will install is 10 amps,. If the plane is wired with #20 wire or larger, no other breakers are required as any of the wiring on the lighting circuits can handle this amperage.
2. Install the breaker size you have determined from step 1 for the Dual MaxDim Controller power source. From the **WIRE SIZE /CURRENT TABLE**, select the wire size required. If the installation is in an Aircraft, use only MIL-W-16878E/4 Type E, Teflon insulated, Silver-Plated Copper Wire, or equivalent
3. Run the supply source wire from the Breaker to the MaxDim controller positive (POS) terminal. Then Select and install a Blue Female crimp on ring connector on the end of the supply source wire. Using a screw and a washer, connect the Blue ring connector onto the POS male connector on the MaxDim controller.
4. Using the same technique that was used with the supply source wire, run a wire from the male GND terminal on the MaxDim to system ground. The common (GND) wire is simply a signal wire used by the unit. It does not carry heavy currents during operation. Use a Red Female crimp on ring connector for this wire. Using a screw and a washer, connect the Red ring connector onto the GND terminal of the MaxDim.
5. Again, using the same technique that was used with the source wire, run a wire from the output CKT #1 for the CKT #1 dimming circuit. Select and install a Blue Female ring connector on the end of the CKT #1 wire.
6. Again, using the same technique that was used with CKT #1, run a wire from output CKT #2 for the CKT #2 dimming circuit.

INSTALLATION:

1. The bushing on the MaxDim is long enough that it can be installed with 2 nuts, one behind the panel on the device and one on the panel side, both set to allow the proper length shaft exposure to accommodate the knobs. Then tightened to secure the MaxDim. Note: Do not over tighten.
2. Locate a convenient place for the Dual MaxDim Control.
3. Determine the type of installation that will meet your needs in terms of panel thickness, and location.
4. Drill the first one 3/8" at the location where the center of the Dimmer is desired. If needed, drill the second (anti-rotation) hole (11/64"), offset to the left from the first 3/8". A template is provided for this type of installation where the MaxDim sits directly on the panel.
5. Install the Dual Knob set using the provided 1/16 in hex wrench.

FUNCTIONAL TEST:

1. Turn the dual knobs fully counter clockwise and apply power to the system.
2. Slowly rotate the each knob clockwise and the Lamp Dimmer Circuits will activate . With a continued clockwise rotation the lamps will increase in intensity.
3. Fully Counterclockwise removes the voltage to the Lamp Dimmer Circuit. The Dual MaxDim circuit voltages are continuously variable from off to full on.

**General Engineering Data Regarding Wire Sizes and Current Capacities Capacity Data
WIRE AND CABLE DERATING CRITERIA FROM MIL-STD-975**

AWG	Diameter	Diameter	Ohms Per	Ohms Per	Maximum	AWG	Derated Current	
Gauge	Inches	mm	1000 Ft	km	Ampere	Gauge	Single	Bundled
14	0.0641	1.6281	2.525	8.282	32	14	19.0	8.5
15	0.0571	1.4503	3.184	10.4435	28	15	16.6	7.4
16	0.0508	1.2903	4.016	13.1725	22	16	13.0	6.5
17	0.0453	1.1506	5.064	16.6099	19	17	11.2	5.6
18	0.0403	1.0236	6.385	20.9428	16	18	9.2	5.0
19	0.0359	0.9119	8.051	26.4073	14	19	8.1	4.4
20	0.032	0.8128	10.15	33.292	11	20	6.5	3.7
21	0.0285	0.7239	12.8	41.984	9	21	5.3	3.0
22	0.0254	0.6452	16.14	52.9392	7	22	4.5	2.5

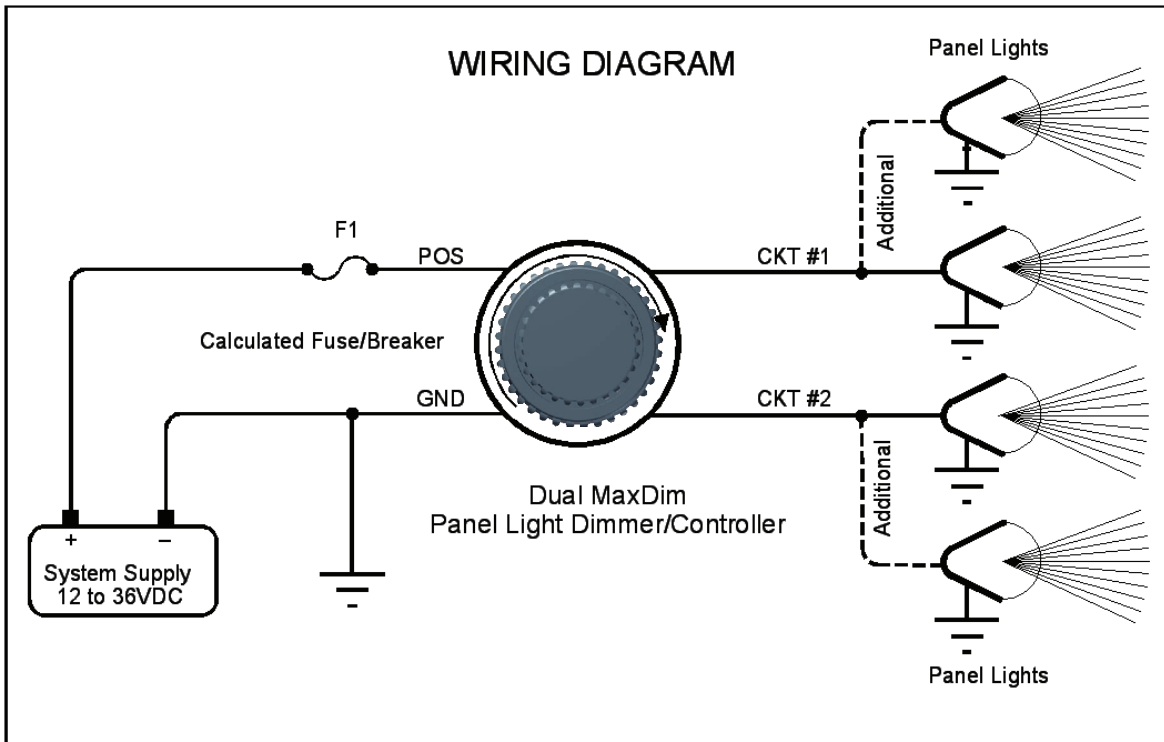

DUAL MAXDIM 9100-001-D SPECIFICATIONS

Voltage Range: 12 to 35VDC

Controlled Output: 0 to 12/35 VDC

Total Capacity:

Max Current: 25 A

- 300 Watts @12 VDC
- 600 Watts @ 24 VDC
- 900 Watts @ 36 VDC

CKT #1: Max Current: 12.5 A

- 150 Watts @12 VDC
- 300 Watts @ 24 VDC
- 450 Watts @ 36 VDC

CKT #2: Max Current: 12.5 A

- 150 Watts @12 VDC
- 300 Watts @ 24 VDC
- 450 Watts @ 36 VDC

Operating Temperature range: -30°C to +65°C

Internal Temperature Protect: +85°C

Storage Temperature: -40°C to +100°C

Maximum Internal Temperature: @15 A

+15 °C above Ambient.

Enclosure Material: Bayer FR 110 Resin

Meets UL 94 Flame Rating: V-2 (0.03in) V-0 (0.059in) 5VB (0.098in) 5VA (0.13in)

Potentiometers Rotation: 270 Deg,

Rotational Life: 500KTurns

Approvals: ★

FAA PMA STC SA01800SE

RTCA/DO-160E Tested/Qualified EMI

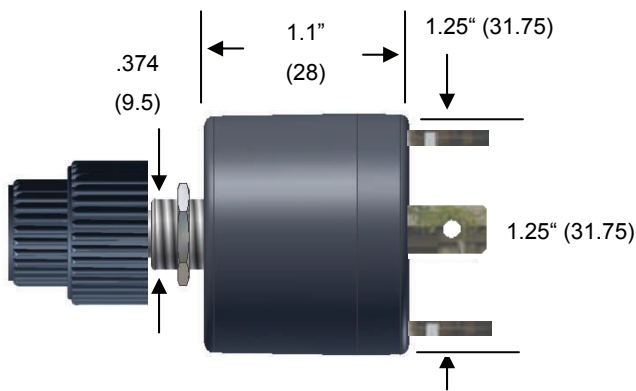

Weight: 1 oz (28g)

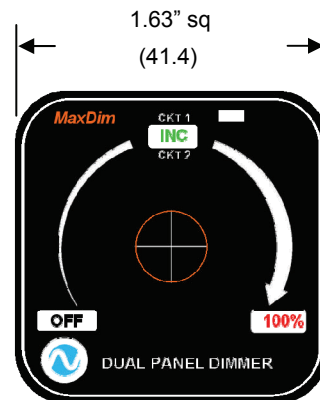

Seaton Engineering Corp.

Spokane Valley, WA 99016

509.928.0633

CAUTION

Most EFIS, GPS, etc. equipment with screens have their own dimmer control and only the steam gauge instruments and panel lights are controlled by an independent dimmer controller. However, the installing technician and the owner must perform a post installation check for proper function and verification of compatibility with any existing equipment that might appear on these airplanes. With the possibility that there might be Electronic Flight Instrument Systems (EFIS) tied into the existing dimmer circuitry, the FAA has advised that the installing Technician and owner verify that they cannot dim any (EFIS) all the way to zero, so there is no danger of failure of this simple dimmer causing all the (EFIS) displays/instruments to be black. If this incompatibility exists the (EFIS) must be removed from the dimming circuit.

FAA REQUIREMENTS

Amend the weight and balance records and make the necessary log book entry. Complete an FAA form 337 showing the installation of this equipment in accordance with the STC instruction and submit one copy to the FAA and one copy to the aircraft owner. File all data and a copy of the STC with the aircraft records.

INSTRUCTIONS FOR CONTINUED AIRWORTHINESS

The Airworthiness Limitations section is FAA approved and specifies maintenance required under Part 43.16 and 91.403 of the FAR's unless and alternative program has been FAA approved. **Airworthiness Limitation:** MaxDim P/N 9100-001-D Light Dimming Controllers, manufactured by Seaton Engineering Corporation have no repairable parts and if a failure occurs, the part must be replaced in its entirety.

ONE YEAR LIMITED WARRANTY

SEC will repair or replace, at its expense and at its option any device manufactured by SEC which in the normal use has proven to be defective in workmanship or material, provided that the customer returns the product prepaid to SEC along with proof of purchase of the product within one year and provides SEC with reasonable opportunity to verify the alleged defect by inspection. SEC will not be responsible for any asserted defect which has resulted from misuse, abuse or over stressing above the published specifications. SEC will under no circumstances be liable for incidental or consequential damages resulting from the defective products This warranty is SEC's Sole warranty and sets forth the customer's exclusive remedy, with respect to defective products; all other warranties, express or implied, whether of merchantability, fitness for purpose, or otherwise, are expressly disclaimed by SEC.

Seaton Engineering Corp. Spokane Valley, WA